



## *Specification for Approval*

- DEVICE NUMBER: BL-HJLBHG8O032N

**SAMPLES  
ATTACHED AREA**

DATE \ PAGE	1	2	3	4	5	6	7	8	9	10	CONTENTS
2019/6/6	1.0	1.0	1.0	1.0	1.0	1.0	1.0	1.0	1.0	1.0	Initial Released
2019/6/11	1.1	1.1	1.1	1.1	1.1	1.1	1.1	1.1	1.1	1.1	Upgrade SPEC

**FOR CUSTOMER'S APPROVAL STAMP OR SIGNATURE**

APPROVED	PURCHASE	MANUFACTURE	QUALITY	ENGINEERING

佰鴻工業股份有限公司  
 BRIGHT LED ELECTRONICS CORP.  
 新北市板橋區和平路 19 號 3 樓  
 3F., No.19, He Ping Road,  
 Ban Qiao Dist., New Taipei City,  
 Taiwan  
 Tel: +886-2-29591090  
 Fax: +886-2-29547006/29558809  
[www.brtled.com](http://www.brtled.com)

ISSUED	APPROVED	PREPARED
張孝嚴	謝皓翔	熊燦芬

### ● Features:

1. Emitted Color: Red, Blue ,Green and IR.
2. Lens Appearance: Water Clear.
3. 3.5x2.8x1.3mm standard package.
4. Suitable for all SMT assembly methods.
5. Compatible with infrared and vapor phase reflow solder process.
6. Compatible with automatic placement equipment.
7. This product doesn't contain restriction Substance, comply ROHS standard.

### ● Package Dimensions:

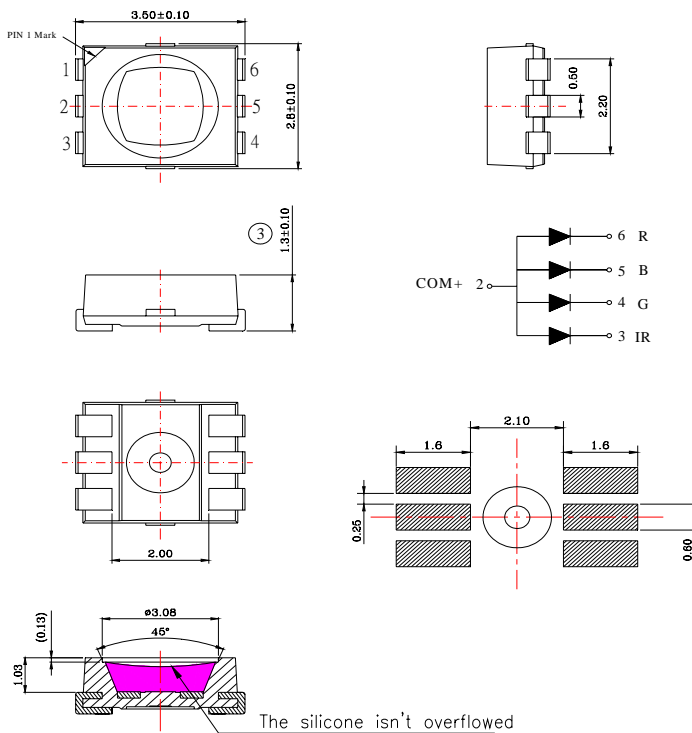

### NOTES:

1. All dimensions are in millimeters.
2. Tolerance is  $\pm 0.10$ mm unless otherwise specified.
3. Specifications are subject to change without notice.

### ● Applications:

1. Backlighting: LCDs, Key pad advertising.
2. Status indicators: Consumer & industrial electronics.
3. General use.

### Absolute Maximum Ratings(Ta=25°C)

Parameter	Symbol	Color	Rating	Unit
Power Dissipation	P <sub>D</sub>	Red	125	mW
		Green	180	
		Blue	180	
		IR	100	
Forward Current	I <sub>F</sub>		50	mA
Peak Forward Current* <sup>1</sup>	I <sub>FP</sub>		100	mA
Reverse Voltage	V <sub>R</sub>		5	V
Operating Temperature	T <sub>opr</sub>		-40°C~85°C	-
Storage Temperature	T <sub>stg</sub>		-40°C~100°C	-

\*<sup>1</sup>Condition for I<sub>FP</sub> is pulse of 1/10 duty and 3 msec width.

### ● Electrical and optical characteristics(Ta=25°C)

Parameter	Symbol	Condition	Color	Min.	Typ.	Max.	Unit
Forward Voltage	V <sub>F</sub>	I <sub>F</sub> =20mA	Red	1.8	2.0	2.5	V
			Green	2.8	3.1	3.6	
			Blue	2.8	3.2	3.6	
			IR	1.2	1.4	2.0	
Luminous Intensity	I <sub>v</sub>	I <sub>F</sub> =20mA	Red	475	900	1600	mcd
			Green	317	700	1070	
	I <sub>e</sub>		Blue	140	220	475	mW/sr
			IR	2.57	3.5	7.07	
Peak Wavelength	λ <sub>p</sub>	I <sub>F</sub> =20mA	Red	-	620	-	nm
			Green	-	525	-	
			Blue	-	470	-	
			IR	840	850	860	
Dominant Wavelength	λ <sub>d</sub>	I <sub>F</sub> =20mA	Red	619	-	630	nm
			Green	520	-	530	
			Blue	465	-	475	
			IR	-	-	-	
Spectral Line Half-width	Δλ	I <sub>F</sub> =20mA	Red	-	25	-	nm
			Green	-	30	-	
			Blue	-	30	-	
			IR	-	45	-	
Reverse Current	I <sub>R</sub>	V <sub>R</sub> =5V	Red	-	-	40	μA
			Green	-	-	4	
			Blue	-	-	4	
			IR	-	-	8	
Viewing Angle	2θ <sub>1/2</sub>	I <sub>F</sub> =20mA	-	-	120	-	degree

### ● Typical Electro-Optical Characteristics Curves

Fig.1 RELATIVE INTENSITY VS. WAVELENGTH

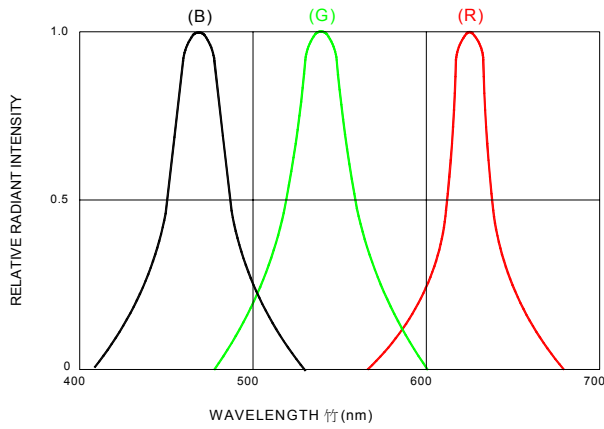

Fig.2 FORWARD CURRENT VS. AMBIENT TEMPERATURE

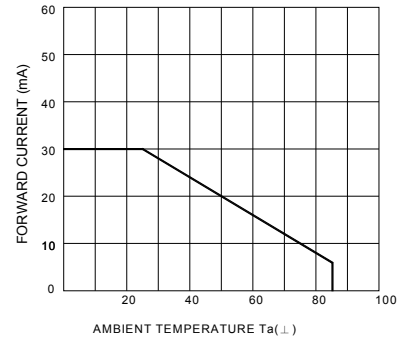

Fig.3 FORWARD CURRENT VS. FORWARD VOLTAGE

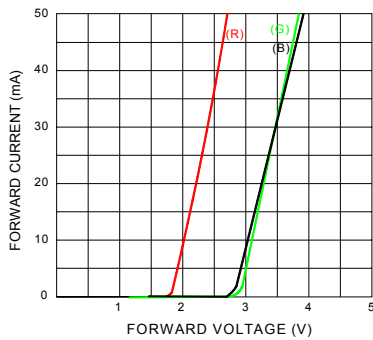

Fig.4 RELATIVE LUMINOUS INTENSITY VS. AMBIENT TEMPERATURE

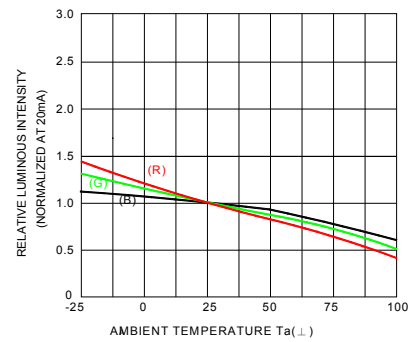

Fig.5 RELATIVE LUMINOUS INTENSITY VS. FORWARD CURRENT

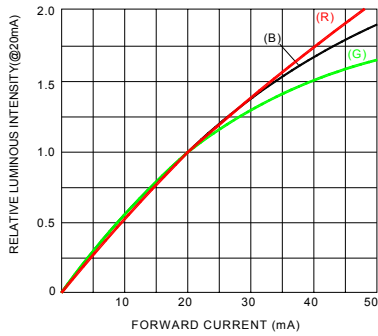
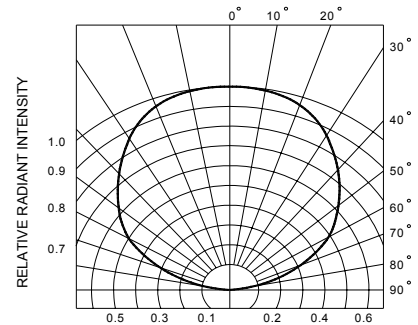

Fig.6 RADIATION DIAGRAM



(IR)

Fig.1 Relative spectral sensitivity vs wavelength

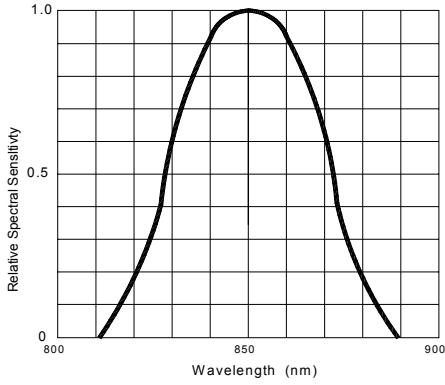

Fig.2 Forward current derating curve vs. ambient temperature

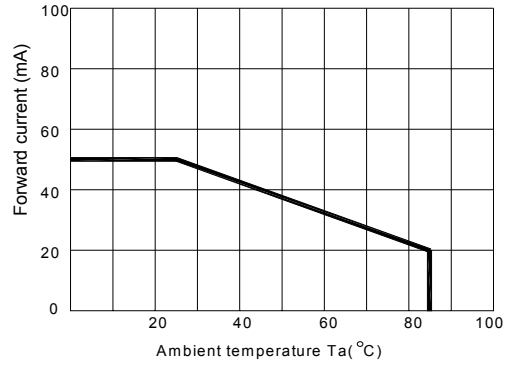

Fig.3 Forward current vs forward voltage

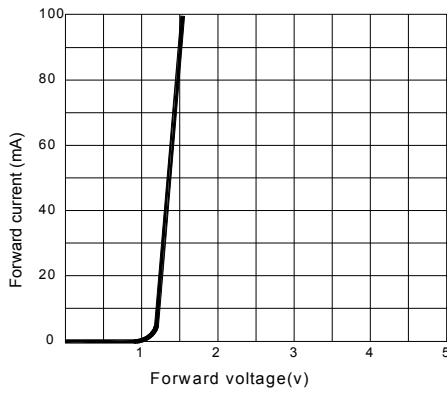

Fig.4 RELATIVE LUMINOUS INTENSITY VS. AMBIENT TEMPERATURE

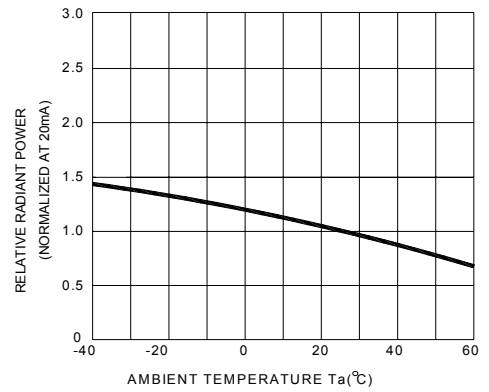

Fig.5 Relative luminous intensity vs forward current

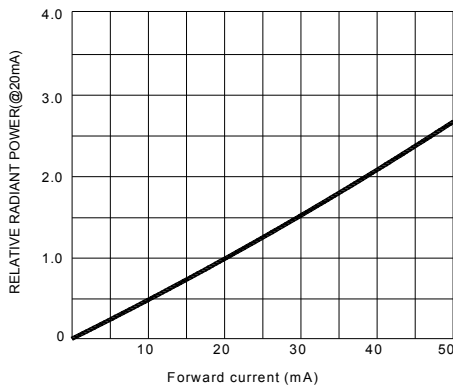
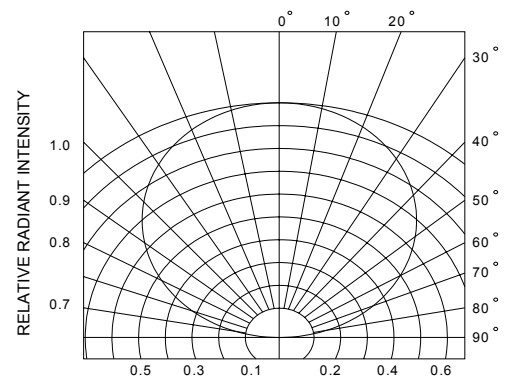

Fig.6 RADIATION DIAGRAM



● Bin Limits (At 20mA)

BIN	R				G				B				O0	
	IV (mcd)		WLD(nm)		IV (mcd)		WLD(nm)		IV (mcd)		WLD(nm)		Ie(Mw/sr)	
	Min	Max	Min	Max	Min	Max	Min	Max	Min	Max	Min	Max	Min	Max
1									140	210				
2					317	475			210	317				
3									317	475				
4									140	210				
5	475	715			475	715			210	317				
6									317	475				
7									140	210				
8					715	1070			210	317				
9									317	475				
10									140	210				
11					317	475			210	317				
12									317	475				
13									140	210				
14	715	1070	619	630	475	715	520	530	210	317	465	475	2.57	7.07
15									317	475				
16									140	210				
17					715	1070			210	317				
18									317	475				
19									140	210				
20					317	475			210	317				
21									317	475				
22									140	210				
23	1070	1600			475	715			210	317				
24									317	475				
25									140	210				
26					715	1070			210	317				
27									317	475				

● BIN : X



BIN CODE

● Tapping and packaging specifications(Units: mm)

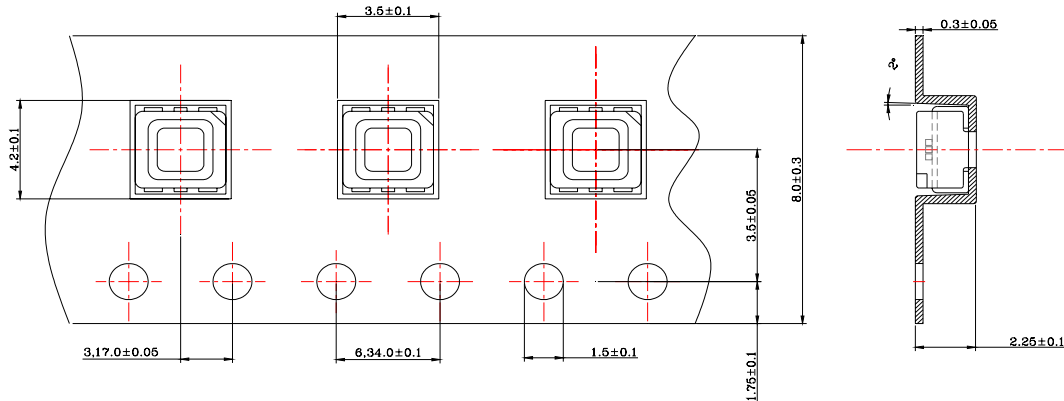

● Package Method:(unit:mm)

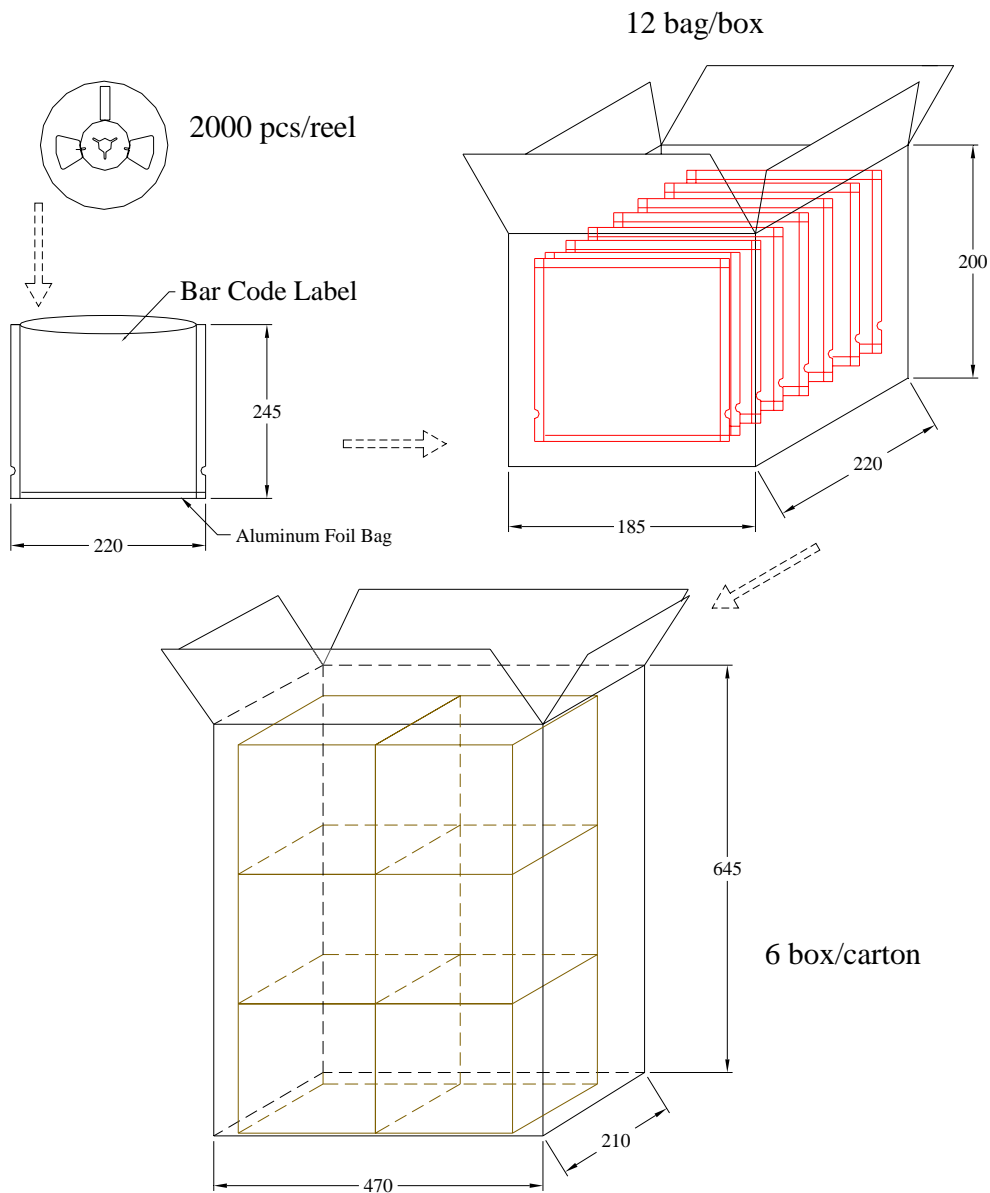

### ● Reliability Test

Classification	Test Item	Reference Standard	Test Conditions	Result
Endurance Test	Operation Life	MIL-STD-750:1026 MIL-STD-883:1005 JIS-C-7021 :B-1	Connect with a power $I_f=20\text{mA}$ $T_a$ =Under room temperature Test time=1,000hrs	0/20
	High Temperature High Humidity Storage	MIL-STD-202:103B JIS-C-7021 :B-11	$T_a=+65^\circ\text{C}\pm 5^\circ\text{C}$ RH=90%-95% Test time=240hrs	0/20
	High Temperature Storage	MIL-STD-883:1008 JIS-C-7021 :B-10	High $T_a=+85^\circ\text{C}\pm 5^\circ\text{C}$ Test time=1,000hrs	0/20
	Low Temperature Storage	JIS-C-7021 :B-12	Low $T_a=-35^\circ\text{C}\pm 5^\circ\text{C}$ Test time=1,000hrs	0/20
Environmental Test	Temperature Cycling	MIL-STD-202:107D MIL-STD-750:1051 MIL-STD-883:1010 JIS-C-7021 :A-4	$-35^\circ\text{C} \sim +25^\circ\text{C} \sim +85^\circ\text{C} \sim +25^\circ\text{C}$ 60min 20min 60min 20min Test Time=5cycle	0/20
	Thermal Shock	MIL-STD-202:107D MIL-STD-750:1051 MIL-STD-883:1011	$-35^\circ\text{C}\pm 5^\circ\text{C} \sim +85^\circ\text{C}\pm 5^\circ\text{C}$ 20min 20min Test Time=10cycle	0/20
	Solder Resistance	MIL-STD-202:201A MIL-STD-750:2031 JIS-C-7021 :A-1	Preheating : 140°C-160°C, within 2 minutes. Operation heating : 260°C (Max.), within 10seconds. (Max.)	0/20

### ● Judgment criteria of failure for the reliability

Measuring items	Symbol	Measuring conditions	Judgement criteria for failure
Forward voltage	$V_F$ ( V )	$I_F=20\text{mA}$	Over $U_x1.2$
Reverse current	$I_R(\mu\text{A})$	$V_R=5\text{V}$	Over $U_x2$
Luminous intensity	$I_v$ ( mcd )	$I_F=20\text{mA}$	Below $SX0.5$

Note: 1.U means the upper limit of specified characteristics. S means initial value.

2. Measurement shall be taken between 2 hours and after the test pieces have been returned to normal ambient conditions after completion of each test.



●IR-Reflow

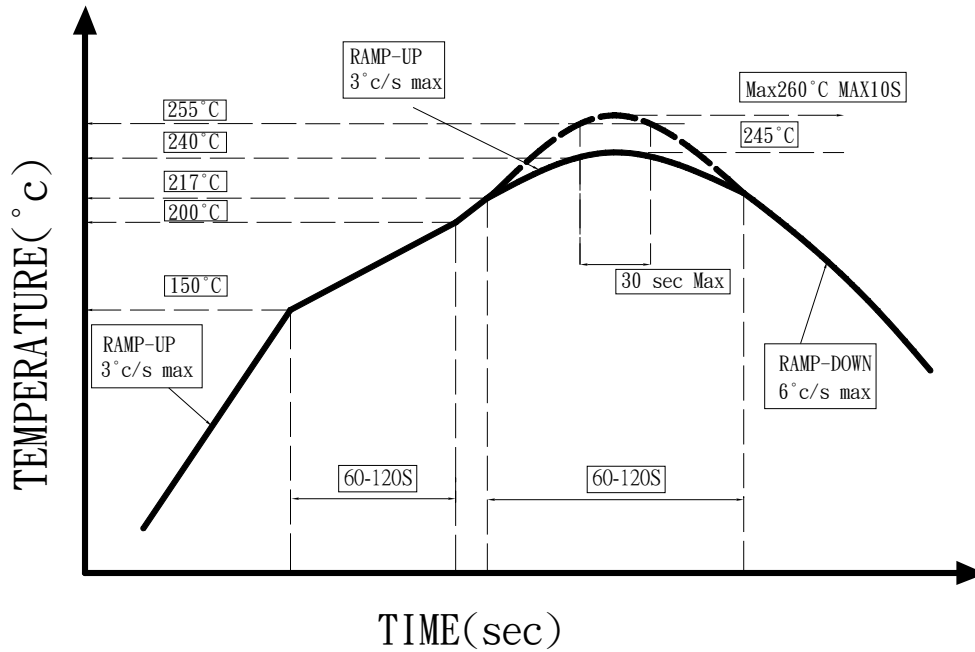

- 1、 Avoid any external stress applied to the resin while the LEDs are at high temperature, especially during soldering.
- 2、 Avoid rapid cooling or any excess vibration during temperature ramp-down process
- 3、 Although the soldering condition is recommended above, soldering at the lowest possible temperature is feasible for the LEDs

●IRON Soldering

350°C Within 3 sec, one time only.

### Handling Precautions

Compare to epoxy encapsulant that is hard and brittle, silicone is softer and flexible. Although its characteristic significantly reduces thermal stress, it is more susceptible to damage by external mechanical force.

As a result, special handling precautions need to be observed during assembly using silicone encapsulated LED products. Failure to comply might lead to damage and premature failure of the LED.

1. Handle the component along the side surfaces by using forceps or appropriate tools.(pic.1)
2. Do not directly touch or handle the silicone lens surface. It may damage the internal circuitry. (pic.2,pic.3)
3. Do not stack together assembled PCBs, containing exposed LEDs. Impact may scratch the silicone lens or damage the internal circuitry. (pic.4)
4. The outer diameter of the SMD pickup nozzle should not exceed the size of the LED to prevent air leaks. The inner diameter of the nozzle should be as large as possible. (pic.5)
5. A pliable material is suggested for the nozzle tip to avoid scratching or damaging the LED surface during pickup. (pic.5)
6. The dimensions of the component must be accurately programmed in the pick-and-place machine to insure precise pickup and avoid damage during production. (pic.5)

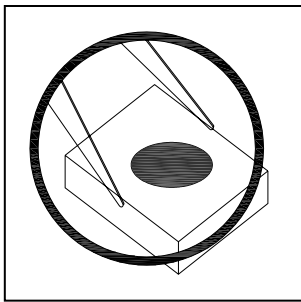

**Pic.1**

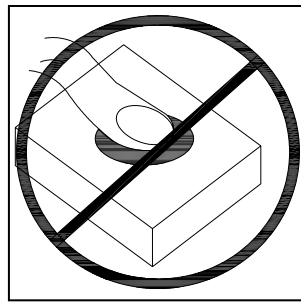

**Pic.2**

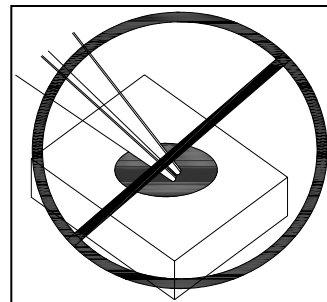

**Pic.3**

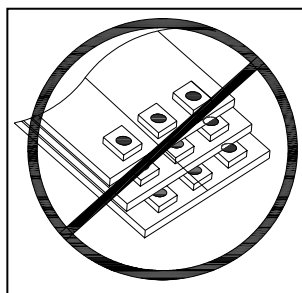

**Pic.4**

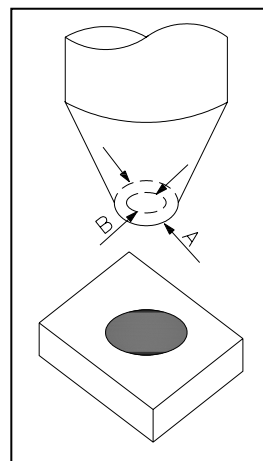

**Pic.5**



# BRIGHT LED ELECTRONICS CORP.

BL-HJLBHG80032N

## ● Notes for designing:

Care must be taken to provide the current limiting resistor in the circuit so as to drive the LEDs within the rated figures. Also, caution should be taken not to overload LEDs with instantaneous voltage at the turning ON and OFF of the circuit.

When using the pulse drive care must be taken to keep the average current within the rated figures. Also, the circuit should be designed so as to be subjected to reverse voltage when turning off the LEDs.

## ● Storage:

In order to avoid the absorption of moisture, it is recommended to solder LEDs as soon as possible after unpacking the sealed envelope.

If the envelope is still packed, to store it in the environment as following:

- (1) Temperature : 5°C-30°C(41°F) Humidity : RH 60% Max.
- (2) After this bag is opened, devices that will be applied to infrared reflow, vapor-phase reflow, or equivalent soldering process must be:
  - a. Completed within 24 hours.
  - b. Stored at less than 20% RH.
- (3) Devices require baking before mounting, if:
  - 2a or 2b is not met.
- (4) If baking is required, devices must be baked under below conditions:
  - 48 hours at 60°C±5°C.

## ● Package and Label of Products:

- (1) Package: Products are packed in one bag of 2000 pcs (one taping reel) and a label is attached to each bag.
- (2) Label:

